

1844 SAINT RAPHAEL

CARACTERISTICS

- Cast aluminium body
- Vandalproof organic glass window
- 316L Stainless steel screws
- Attaches directly to roadway or to recess plate

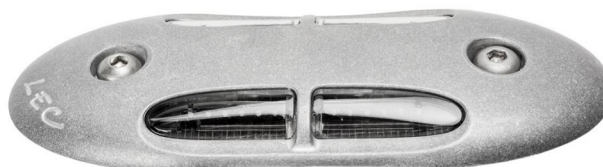

Number of LEDs	24
Type of LEDs	Wide angle 5 mm LEDs (H)
Color(s)	Warm white 3000K (E), Neutral white 4000K (N), Cool white 6000K (W), Red (R), Amber (O), Green (V), Blue (L)

Select your specific requirements with our product configurator, by filtering technical criteria at the following link:
<http://www.lec.fr/1844z-saint-raphael-r129>

APPLICATION

- Marker-lighting

CONFIGURATEUR.EMPLACEMENT

- Ground recessed fittings

CARACTERISTICS

Weight : 360 g

Options of luminous effects

- Non adjustable
- Paralell beam
- Transparent dome (optional)

Power supply - Control

- Cable length: 1 m
- Integrated** : 24V-PWM
- Remote** : 24V-0/10V, 24V-DMX, 24V-DALI

Material

- Marine anodised cast aluminium

Mechanical strength - Waterproofness

- IP69K** pressure water spray (previous registration)
 Protrusion which is an obstacle for 2-wheels vehicles and pedestrians. The unit should be permanently lit to draw attention to the obstacle.
- Withstands low-speed light vehicles traffic
 Certified in compliance with European Standards 60598-2-22 for emergency lighting units
- 2,5T** Resists compression up to 2,5 tons
- IK10 60J** Resists impacts up to 60 joules (IK10)
- IP68** Tight for extended immersion